

Bob Beck's Legacy

HOW TO BUILD YOUR OWN

The following schematic and instructions have been edited from the original handout that Bob Beck made available after his lectures. This handbook now called "The Beck Protocol", is available as a free download or a hardcopy can be purchased.

[Download Beck Protocol Handbook](#)

[Purchase Beck Protocol Handbook](#)

Note: These data are for informational and instructional purposes only and are not to be construed as medical advice. Consult with your licensed health practitioner. Thousands have been built successfully if duplicated exactly as shown.

HOW TO BUILD A BLOOD ELECTRIFICATION UNIT

Proposed Theoretical In-Vivo Blood Pathogen Neutralizing Device

Revision November 24, 1996. Copyright © 1991/1996 Robert C. Beck, D.Sc.

Revised July 2015

Schematic by Bob Beck

This 11/24/1996 page describes a 'Plant Growth Stimulator' improved since my 1991 design. User-tested for over two years, it is solid state (no relays), uses three (not seven) batteries, makes colloids, is much smaller, lighter, silent, with battery saving features. The ionic colloidal silver making function is included in the blood electrification schematic. (See Schematic on page 3)

There are three methods for making ionic colloidal silver - Constant Current, Heating Water and Salt. For this design, the Heating Water Method and Salt Method can be used.

The first section (U1A) of the LM358 dual OP Amp is a 54 (2 x 27 Volts peak per cycle) Volt peak-to-peak square wave oscillator. The second section (U1B) reverses polarity and provides ± 27 Volts DC output of low impedance. This delivers a Bi-Phasic, sharp rise time output of ~ 4 Hz (not critical) for the biological cotton-covered stainless-steel electrodes saturated with salt water before applying. Sharp rise time is considered necessary to provide higher odd harmonics to the stimulus, although "rounded" waveforms will feel different.

The third section is a current-limited 27 Volts DC output from a separate RCA (or 2.5mm) jack for rapid generation of excellent colloidal silver in water. The Heating Water Method increases the conductivity of distilled water. This produces an ionic colloidal silver with a small particle size.

The Salt Method using a pinch of salt was originally recommended to increase the conductivity and speed the making of colloidal silver. This method has been effective for many people but the particle sizes are larger as the silver reacts with the salt to form silver chloride. This solution may not be as effective and with long-term use the risk of argyria, a darkening of the skin, is higher.

Using hot water or salt will not speed the process with a Constant Current unit, as it works independent of the temperature of the water.

OP-Amp section U1A's 4 Hz oscillator frequency is set by C1 (0.1 uF) and R4 (2.4 Meg Ohm). It is configured as a comparator with hysteresis determined by R3 (150k Ohm). Charging and discharging of C1 is done by the 180° out-of-phase signal through R4. R1 and R2 provide a set point 1/2 the V+ to the comparator. This insures a 50% duty cycle square wave with an amplitude of slightly less than the ~27 Volt supply.

U1B, the *second comparator*, is used to invert the output of oscillator U1A. A ~54 Volt peak-to-peak signal will be generated between the OP-Amps due to their outputs being 180° out-of-phase. U1B's current is limited by potentiometer SW1 (100k Ohm) and R5 (820 Ohm) and is set to individual user's comfort.

The *power indicator* circuit consists of a bicolor (Red-Green) LED (LED1) and the series combination of two 18 Volt Zener diodes, D1 & D2, with power limited by C2 (22uF, 35 Volt). This section of the device is automatically disabled when the 3.5mm plug is inserted into its jack. Therefore the LEDs flash only when batteries sum is over ~21 Volts. If LEDs are dim or extinguished, replace with three fresh 9 Volt Alkaline batteries. C2 used as a limiter allows the LED to flicker on at 1/8 second intervals only as the square wave output reverses polarity.

Users find this newer design highly satisfactory, trouble free and most efficient.

[Note: This schematic is not a constant current unit and requires using a heat process to make ionic colloidal silver.]

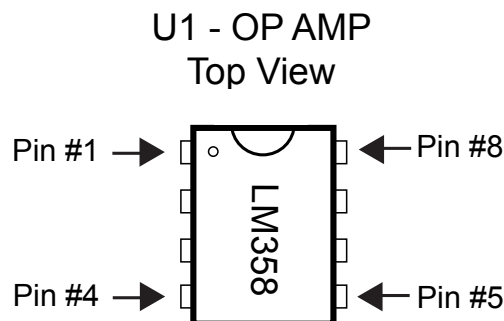

Note: Ensure the IC chip U1 (LM358) is wired correctly. The location of Pin #1 is shown above.

Schematic For Blood Electrification Unit with Colloidal Silver Output

Copyright © 1996 Robert C. Beck, D.Sc.

Revised July 2015

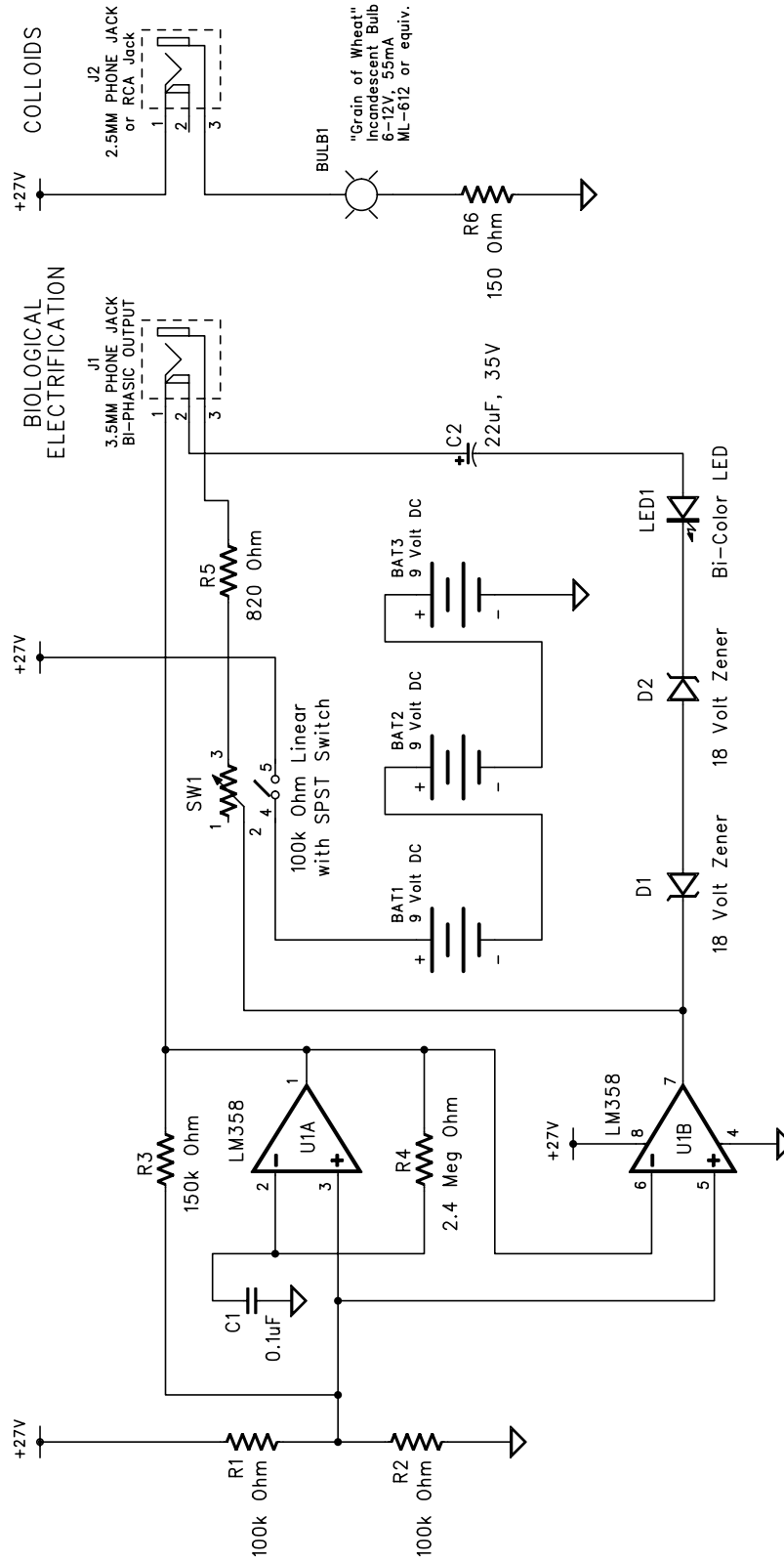

OUTPUT: 4 Hz Square Wave, Bi-Phasic

OUTPUT: Colloidal Silver

Note: This schematic does not use the Constant Current Method and therefore requires using a heat process to make the ionic colloidal silver.

Schematic - Parts List

LM358 CMOS Operational Amplifier (OP-AMP) chip (generic)	U1
2 x 100k Ohm ¼ watt 5% resistor	R1, R2
150k Ohm ¼ watt 5% resistor	R3
2.4 (or 2.2) Meg Ohm ¼ watt 5% resistor	R4
820 Ohm ¼ watt 5% resistor	R5
150 Ohm ¼ watt 5% resistor	R6
100k Ohm linear taper potentiometer with SPST switch	SW1
0.1uF 50 V (or higher) ceramic capacitor	C1
22uF 35 V (or higher) electrolytic capacitor	C2
2 x 18 Volt Zener diodes, ½ Watt (NTE5027A)	D1, D2
Bulb, 6-12V @ 55mA or 6.3V @ 0.075A, Type ML612 or 7377	BULB1
Bicolor LED Red/Green	LED1
Jack for electrode leads (3.5mm or 1/8" mono-phone jack)	J1
Jack for silver wire leads (2.5mm or 3/32" mono-phone jack)	J2
3 x Alkaline 9 Volt batteries, type 1604 etc.	BAT1-3
3 x 9 Volt battery snaps (clip-on connectors)	
Misc. wire, solder, etc.	
If used; Box; Bread Board; 8-Pin IC Socket	
Lead wire with 3.5 mm plug, 6 ft., Mouser or Calrad Electronics	
Electrodes, stretch elastic, Velcro, cotton flannel, alligator clips, etc.	

For all components listed above, check your local electronics store. If a part is not available, they may have a suitable replacement.

Updated Blood Electrification Unit with Constant Current Ionic Colloidal Silver

The only change to this design is using Constant Current Output for making ionic colloidal silver. There are three methods for making ionic colloidal silver - Constant Current, Heating Water and Salt. For this design, the Constant Current Method is used. With Constant Current, room temperature distilled water can be used. The process is not accelerated by heating the water or adding salt. Constant Current produces a high quality silver solution that is largely ionic silver. The ionic form insures a very tiny particle size - a form the body seems to readily absorb.

The first section (U1A) of the LM358 dual OP Amp is a 54 (2 x 27 Volts peak per cycle) Volt peak-to-peak square wave oscillator. The second section (U1B) reverses polarity and provides ± 27 Volts DC output of low impedance. This delivers a Bi-Phasic, sharp rise time output of ~ 4 Hz (not critical) for the biological cotton-covered stainless-steel electrodes saturated with salt water before applying. Sharp rise time is considered necessary to provide higher odd harmonics to the stimulus, although "rounded" waveforms will feel different. See page 2 for a diagram of U1.

The third section is a current-limited 27 Volts DC output from a separate RCA (or 2.5mm) jack for rapid generation of excellent colloidal silver in water. A three minute cycle in 8 oz. of room-temperature water makes a ~ 3 -5 ppm concentration. [This timing was based on adding salt to the water to increase conductivity. Later, heating the water was recommended, instead, to keep particle size smaller.]

OP-Amp section U1A's 4 Hz oscillator frequency is set by C1 (0.1 μ F) and R4 (2.4 Meg Ohm). It is configured as a comparator with hysteresis determined by R3 (150k Ohm). Charging and discharging of C1 is done by the 180° out-of-phase signal through R4. R1 and R2 provide a set point 1/2 the V+ to the comparator. This insures a 50% duty cycle square wave with an amplitude of slightly less than the ~ 27 Volt supply.

U1B, the *second comparator*, is used to invert the output of oscillator U1A. A ~ 54 Volt peak-to-peak signal will be generated between the OP-Amps due to their outputs being 180° out-of-phase. U1B's current is limited by potentiometer SW1 (100k Ohm) and R5 (820 Ohm) and is set to individual user's comfort.

The *power indicator* circuit consists of a bicolor (Red-Green) LED (LED1) and the series combination of two 18 Volt Zener diodes, D1 & D2, with power limited by C2 (22 μ F, 35 Volt). This section of the device is automatically disabled when the 3.5mm plug is inserted into its jack. Therefore the LEDs flash only when batteries sum is over ~ 21 Volts. If LEDs are dim or extinguished, replace with three fresh 9 Volt Alkaline batteries. C2 used as a limiter allows the LED to flicker on at 1/8 second intervals only as the square wave output reverses polarity.

Users find this newer design highly satisfactory, trouble free and most efficient.

Updated Schematic For Blood Electrification Unit with Constant Current Colloidal Silver Output

Copyright © 2015 Foundation for Health Research

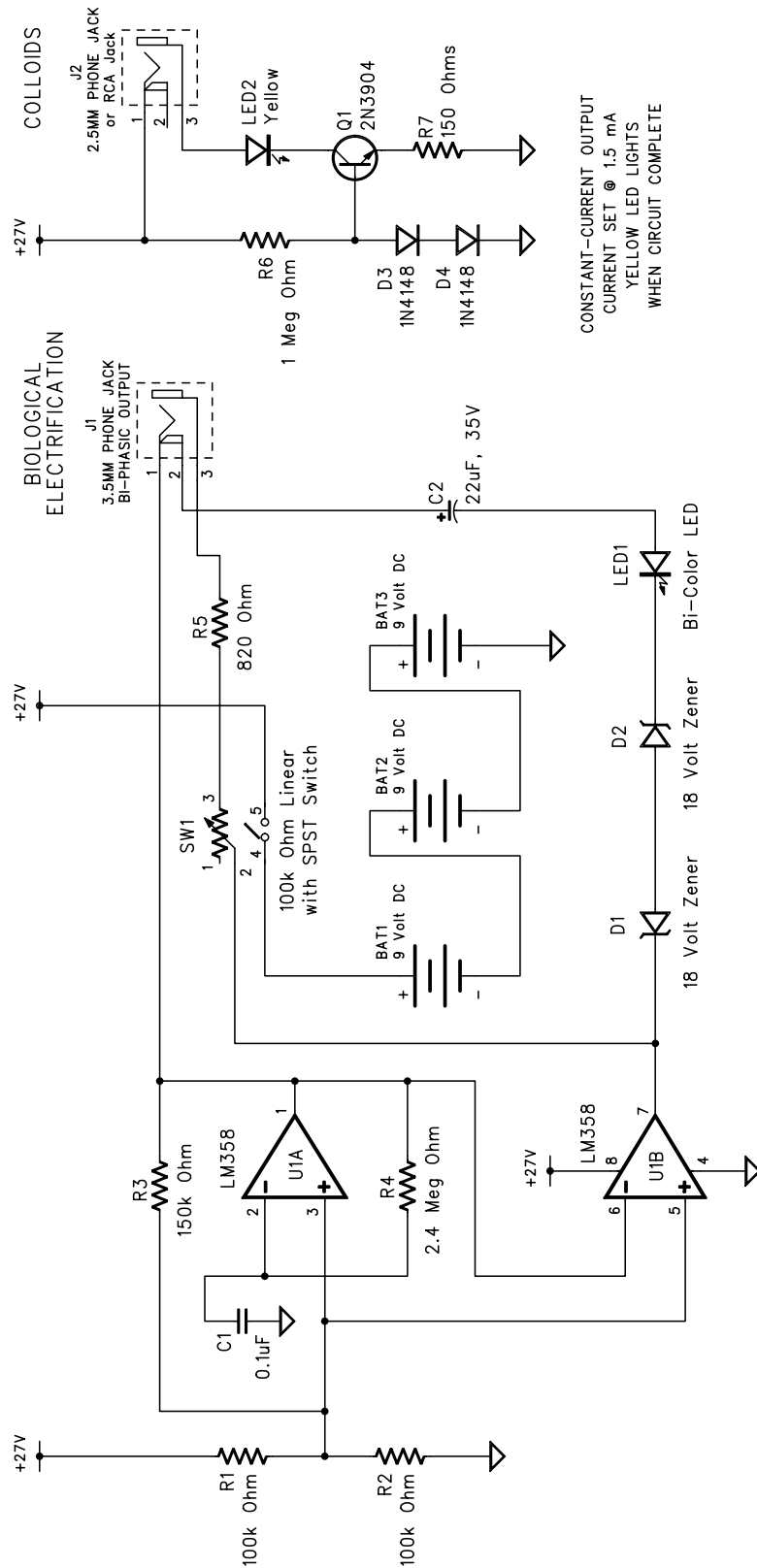

CONSTANT-CURRENT OUTPUT
CURRENT SET @ 1.5 mA
YELLOW LED LIGHTS
WHEN CIRCUIT COMPLETE

OUTPUT: Colloidal Silver

OUTPUT: 4 Hz Square Wave, Bi-Phasic

Note: This schematic uses the Constant Current Method to make the ionic colloidal silver.

Disclaimer: Please understand we are not health practitioners. By reading the information contained on our website, you are agreeing that you take full responsibility for any decision you make because of it. Any information shared is based on science, hearsay, testimonials, lay people and professionals. The content provided on this site is for informational purposes only and is not intended to diagnose, treat or cure any medical condition. Please consult your health practitioner. Results are not typical.

Updated Schematic - Parts List

LM358 CMOS Operational Amplifier (OP-AMP) chip (generic)	U1
2 x 100k Ohm ¼ watt 5% resistor	R1, R2
150k Ohm ¼ watt 5% resistor	R3
2.4 (or 2.2) Meg Ohm ¼ watt 5% resistor	R4
820 Ohm ¼ watt 5% resistor	R5
1 Meg Ohm ¼ watt 5% resistor	R6
150 Ohm ¼ watt 5% resistor	R7
2N3904 NPN Switching Transistor, TO-92	Q1
100k Ohm linear taper potentiometer with SPST switch	SW1
0.1uF 50 V (or higher) ceramic capacitor	C1
22uF 35 V (or higher) electrolytic capacitor	C2
2 x 18 Volt Zener diodes, ½ Watt (NTE5027A)	D1, D2
2 x 1N4148 Rectifier Diode	D3, D4
Bicolor LED Red/Green	LED1
Yellow LED	LED2
Jack for electrode leads (3.5mm or 1/8" mono-phone jack)	J1
Jack for silver wire leads (2.5mm or 3/32" mono-phone jack)	J2
3 x Alkaline 9 Volt batteries, type 1604 etc.	BAT1-3
3 x 9 Volt battery snaps (clip-on connectors)	
Misc. wire, solder, etc.	
If used; Box; Bread Board; 8-Pin IC Socket	
Lead wire with 3.5 mm plug, 6 ft., Mouser or Calrad Electronics	
Electrodes, stretch elastic, Velcro, cotton flannel, alligator clips, etc.	

For all components listed above, check your local electronics store. If a part is not available, they may have a suitable replacement.

HOW TO BUILD A MAGNETIC PULSE GENERATOR

Suggestions for Acquiring and Using an Inductively Coupled Magnetic Pulse Generator for Theoretical Lymph and Tissue Pathogen Neutralization

Revision January 15, 1997. Copyright © 1991/1997 Robert C. Beck, D.Sc.

Revised January 2015

In keeping with do-it-yourself inexpensive hypothetical approaches to self-help, the simplest and most rapid means for obtaining a capacitor-discharge theoretical magnetic pulse **lymph and tissue pathogen neutralizer** would be to find and modify a used functioning portable battery *and* AC powered electronic flash (strobe light) for cameras. These are acquired at swap meets, yard sales, pawn shops, or in junk boxes at used camera stores. Or purchase a new Vivitar (brand) model 1900 carried at some professional camera stores. This compact, light weight, inexpensive, rapid recharging flash is only 17.5 Watt*Seconds (Joules: calculated as $\frac{1}{2} CV^2$ where C is in microFarads, mF or mfd., and V is in Volts) power but is readily available and easily modified. It works well enough for casual use but runs on batteries only so has greater operating expense than an AC/DC unit.

California swap meet prices for used strobes range from \$4.00 to about \$18.00. One Sunday the writer found a dozen AC/DC strobes, all in good working condition. Carry four AA batteries with you so you can test flash units before purchasing. Almost any brand or model of comparable output power (17 to 35 Watt*Seconds) should work. **Preferably select one with 115VAC as well as battery operating (DC) capability.**

First wind the applicator coil. Junk VHS videocassette reels are cheap, plentiful and adequate for this application. Remove 5 screws from shell, remove reels and discard shell. Be SURE alternative spools (if used) are non-conductive (plastic) or system will not work. Avoid shorter length VHS tape reels which may have center hubs larger than 1" dia. and won't hold sufficient wire. Drill $\frac{1}{4}$ " holes through hub and through center of flange(s). Make two 4" discs from $\frac{1}{4}$ " thick plastic, metal, plywood or *stiff* fiberboard, drill $\frac{1}{4}$ " center holes and another $\frac{1}{4}$ " hole off-center so coil's inside lead wire can be pulled through. These "stiffeners" must sandwich reel's flanges tightly so they won't warp or split as wire pressure builds up while winding progresses. A 2" (or longer) $\frac{1}{4}$ -20 machine nut and bolt with washers through centers will clamp flange stiffeners and reel and also provide a shaft to hold in a variable speed drill motor or similar winding device if used. Remove bolt and stiffeners when finished.

Specifications: Completely fill tape spool with #14 or #16 enameled copper magnet wire (130 to 160 turns) wound into the 1" dia. hub and 3- $\frac{1}{2}$ " OD spool with a gap width for wire of $\frac{5}{8}$ ". Scrape enamel insulation $\frac{1}{2}$ " from ends and tin. Pull inside end of magnet wire through hub and stiffener and to outside. About 1- $\frac{1}{2}$ " should fill spool. Remove bolt, stiffeners, and finished coil. Now solder ends of 4 ft. of *heavy* two-wire extension cord to each side of coil. A #14 finished coil weighs ~1 lb. 3 oz., has ~0.935 millihenry inductance, 0.34 Ohm resistance, and takes ~20 minutes to hand wind or ~3

minutes with drill motor. An excellent alternative is an AMS brand air-core crossover inductor for home audio, MCM Electronics, Centerville, OH 45459, (800) 543-4330 catalog #50-940, 16 gauge, 0.58 Ohm, 2.5mH, 2-7/8" dia.

Strobe modification consists simply of wiring the finished applicator coil with 4 ft. leads in series between either flash tube electrode. Be extremely cautious when working with case open because a strobe's capacitor can hold a residual high-voltage charge for a long time even when "off." Before modifying and to avoid shock, short out the capacitor by placing clip leads directly across the flash tube. Remember to remove this shunt later. To install coil, unsolder one wire from flash tube electrodes and connect one lead wire from coil to that side of tube. Connect the other lead from coil to the wire you just removed from tube. Insulate connections with tape. This places your coil *in series* with the flash tube and enables the lamp to act as an ionized gas relay or "thyatron" that dumps most of capacitor's stored energy through coil when fired. Lamp will still flash but less brightly. Cover flash window with black paper. Melt wire-slot with soldering iron. Replace case. You're done!

Is it working properly? A good way to test strength of pulsed magnetic energy is to lay a thin steel washer (one strongly attracted to magnet) flat on top of coil, 1/2" off center. A 1" dia. "fender" washer with 1/8" center hole works well. Let the flash unit charge for about ten seconds or until the strobe's "ready light" comes on then push flash button and see how the washer is "kicked" by Eddy current repulsion. A 35 Watt*Second strobe repels this washer over a foot vertically. Think of your pulsed coil as the "primary" of a transformer and anything conductive nearby (living tissue included) as the "secondary" in which current is induced when cut by coil's time-varying magnetic lines of flux. Your do-it-yourself magnetic pulse generator delivers a measurable output intensity *several thousand times* more powerful during each cycle than \$7,000 German "Magnetotrons®", Elecsystem "Biotrons®", or Canada's "Centurion®" devices widely exhibited at holistic medical expos, none of which is nearly powerful enough for pathogen neutralization. Pulsers are also functionally similar to the "Diapulse®" miracle-working healing modality when coil is applied over liver and other organs. Regular permanent magnets no matter how powerful in Gauss absolutely will **not** work for this application regardless of claims since only a **time varying** field induces a significant current in tissue. Magnetic fields and therefore induced currents penetrate *all* body cells, bones and tissues in proximity to coil and can theoretically neutralize electro-sensitive pathogens and viruses such as herpes B, HIV, hepatitis, Epstein-Barr and possibly many others as yet undiscovered that hide *within* nerve sheaths and are therefore untouchable via immune system, white cells or injectables. This may account for the impossibility of curing many known chronic infections via pharmaceuticals, antibiotics, or any presently known conventional treatments other than electrotherapy. Use pulser on body sites daily. This pulser is safe to use anywhere on the head and body except with cardiac pacemaker users. Zap sites at ~10 second intervals for ~20 minutes daily.

To use press fully insulated coil flat against body over lymph glands and other selected locations. Let strobe build up to full charge (about 4 to 10 seconds between pulses) and flash while pressing coil over each selected site. Subjects will feel no physical sensations except for light "thumps" during this phase of electrification. **Exposure levels are considered safe because intensity of this magnetic pulser is much lower than Magnetic Nuclear Resonance Imaging in routine use of tens of**

thousands of patients. But should subject feel “headachy”, nauseous, sluggish, or display flu-like symptoms after exposures with either of these two devices, reduce number of pulses or duration of blood clearing process and drink ozonated water. If immune system is very badly damaged, you may need to repeat all routines after several months to insure neutralization. *When using, keep coil several feet away from credit cards, watches, magnetic tape, computers, floppy disks, homeopathic remedies, etc., since its powerful magnetic field can de-gauss and erase magnetic data as well as subtle energy potentized medicines.* As an unanticipated serendipity, pulsers are reported to erase deeply rooted lymph and tissue pathology and possibly even classical “miasmas” as well as many other microbes, fungi, bacteria, parasites and viruses. Flash should preferably be used with AC power to save battery costs since you’ll only get about 40 full pulses per new set of alkaline batteries. For sanitary purposes, enclose coil in plastic zip-lock discardable sandwich bag. When treating numerous subjects if there’s no AC adapter it is economical to utilize a small rechargeable lead-acid “motorcycle” battery.

I recommend the manufacturer’s pulser [SOTA Instruments Inc.] that is far superior to making one with a photo flash. The outputs as measured on a Tektronics TDS 210 Digital Real-Time Oscilloscope, and Wavetek AD105 Clamp-On RMS Ammeter are: Energy Storage Capacitor: 600uF, 450 Volts DC, Typical Energy Storage: 36.75 Joules (Watt*Seconds), Maximum Energy Storage: 42.18 Joules (Watt*Seconds), Typical Peak Charge Voltage: 350 Volts DC, Maximum Peak Charge Voltage: 375 Volts DC, Minimum Peak Current Discharge into Coil: 150 Amps RMS, Pulse Rise Time: <1.8 uS (microseconds), Pulse Duration: ~2.5mS (milliseconds), Main Coil Inductance: ~2.5mH (milli-henries), Flux Density: 40,500 Ampere*Turns, Peak Magnetic Field Output: ~6,000 Gauss (~6 kilo Gauss) as measured with a F.W. Bell 5080 Tesla Meter, Minimum Number of Pulse Discharges 30 Million (30,000,000). It penetrates about 9 inches through tissue.